

SC 300

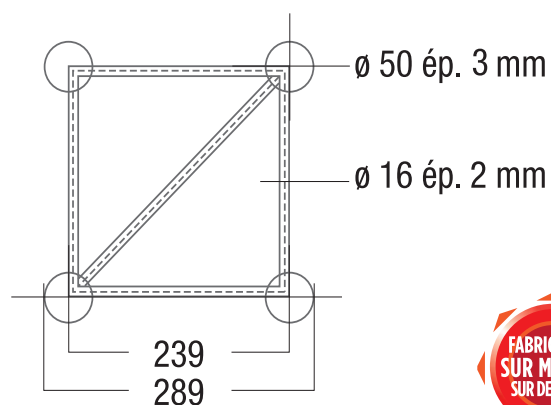

CHARGES MAXIMALES (1/100) *							
		Q	P1	P1 P2	P3 P3 P3	P4 P4 P4 P4	
Portée (m)	Flèche (mm)	Q (kg/ml)	P1 (kg)	P2 (kg/pt2)	P3 (kg/pt3)	P4 (kg/pt4)	SW (kg)
1	10	1543	1543	772	514	386	7
2	20	768	1537	768	512	384	13
3	30	510	1530	765	510	383	20
4	40	381	1169	762	508	381	26
5	50	303	924	701	467	379	33
6	60	252	758	578	385	322	39
7	70	189	637	489	326	273	46
8	80	143	546	422	281	236	52
9	90	112	473	369	246	207	59
10	100	89	413	326	217	183	65
11	110	73	363	290	193	163	72
12	120	60	320	260	173	146	78
13	130	50	283	234	156	132	85
14	140	42	250	211	140	120	91
15	150	36	221	190	127	108	98
16	160	31	195	172	115	98	104
17	170	27	171	156	104	90	111
18	180	23	149	141	94	81	117
19	190	20	128	127	85	74	124
20	200	17	109	108	76	65	130

CHARGES PRÉCONISÉES (1/300) *							
		Q	P1	P1 P2	P3 P3 P3	P4 P4 P4 P4	
Portée (m)	Flèche (mm)	Q (kg/ml)	P1 (kg)	P2 (kg/pt2)	P3 (kg/pt3)	P4 (kg/pt4)	SW (kg)
1	3	1543	1543	772	514	386	7
2	7	768	1537	768	512	384	13
3	10	510	1530	765	510	383	20
4	13	381	1169	762	508	381	26
5	17	303	924	701	467	379	33
6	20	252	758	578	385	322	39
7	23	177	637	449	323	254	46
8	27	117	546	335	242	190	52
9	30	80	428	256	185	146	59
10	33	56	329	199	144	114	65
11	37	41	254	155	113	90	72
12	40	30	195	121	89	71	78
13	43	22	148	94	70	56	85
14	47	16	110	72	54	44	91
15	50	12	77	54	41	33	98
16	53	9	50	38	30	25	104
17	57	6	26	25	21	17	111
18	60	4	5	13	12	11	117
19	63	3	N.A	2	5	5	124
20	67	1	N.A	N.A	N.A	0	130

Sous réserve que l'utilisateur ait vérifié au préalable la stabilité au non-basculement de la poutre
 *Bien comprendre les taux de flèche, se reporter page 4